

LUBRICATION ORDER

**ARMY LO 9-2320-280-12**

**AIR FORCE TO 36A12-1A-2091LC-1**

**MARINE CORPS LI 2320-12/8**

19 JUNE 1990

(SUPERSEDES LO 9-2320-280-12, 15 OCT 1986)

TRUCK, UTILITY CARGO/TROOP CARRIER, 1-1/4-TON,  
4X4, M998 (2320-01-107-7155);

TRUCK, UTILITY CARGO/TROOP CARRIER, 1-1/4-TON,  
4X4, W/WINCH, M1038 (2320-01-107-7156);

TRUCK, UTILITY TOW CARRIER, ARMORED, 1-1/4-TON,  
4X4, M966 (2320-01-107-7153);

TRUCK, UTILITY TOW CARRIER, ARMORED, 1-1/4-TON,  
4X4, W/WINCH, M1036 (2320-01-107-7154);

TRUCK, UTILITY TOW CARRIER, W/SUPPLEMENTAL ARMOR,  
1-1/4-TON, 4X4, M1045 (2320-01-146-7191);

TRUCK, UTILITY TOW CARRIER, W/SUPPLEMENTAL  
ARMOR, 1-1/4-TON, 4X4, W/WINCH, M1046 (2320-01-146-71 88);

TRUCK, UTILITY ARMAMENT CARRIER, ARMORED,  
1-1/4-TON, 4X4, M1025 (2320-01-128-9551);

TRUCK, UTILITY ARMAMENT CARRIER, ARMORED,  
1-1/4-TON, 4X4, W/WINCH, M1026 (2320-01-128-9552);

TRUCK, UTILITY ARMAMENT CARRIER, W/SUPPLEMENTAL  
ARMOR, 1-1/4-TON, 4X4, M1043 (2320-01-146-7190);

TRUCK, UTILITY ARMAMENT CARRIER, W/SUPPLEMENTAL  
ARMOR, 1-1/4-TON, 4X4, W/WINCH, M1044 (2320-01-146-7189);

TRUCK, UTILITY: S250 SHELTER CARRIER,  
4X4, M1037 (2320-01-146-7193);

TRUCK, UTILITY S250 SHELTER CARRIER, 4X4,  
W/WINCH, M1042 (2320-01-146-7187);

TRUCK, AMBULANCE: 2-LITTER, ARMORED,  
4X4, M996 (2310-01-111-2275);

TRUCK, AMBULANCE: 4-LITTER, ARMORED,  
4X4, M997 (2310-01-111-2274);

TRUCK, AMBULANCE: 2-LITTER, SOFT TOP,  
4X4, M1035 (2310-01-146-7194)

APPROVED FOR PUBLIC RELEASE DISTRIBUTION IS UNLIMITED

TA 267881

**REFERENCE: TM 9-2320-280-10 AND TM 9-2320-280-20**

All intervals and the related man-hour times are based on normal operations. The man-hour time specified is the time you need to do all the services prescribed for a particular interval.

Hard time intervals may be shortened if your lubricants are contaminated or if you are operating the equipment under adverse conditions, including longer-than-usual operating hours. Hard time intervals may be extended during periods of low activity, though adequate preservation precautions must be taken.

**WARNING**

Drycleaning fluid is flammable and will not be used near an open flame. A fire extinguisher will be kept nearby when the solvent is used. Use only in well-ventilated places. Failure to do this may result in injury to personnel and/or damage to equipment.

Clean fittings before lubricating. Clean parts with drycleaning solvent SD-II (S-753) meeting specification P-D-680. Dry before lubricating. Dotted arrow points indicate lubrication on both sides of equipment. A dotted circle indicates a drain below. Relubricate all items found contaminated after fording.

The lowest level of maintenance authorized to lubricate a point is indicated by one of the following symbols as appropriate: Operator/Crew (C); and Organizational Maintenance (O).

Reporting errors and recommending improvements. (Army) You can help us improve this manual. If you find any mistakes, or if you know of a way to improve the procedures, please let us know. Mail your letter or DA Form 2028 (Recommended Changes to Publications and Blank Forms) directly to: Commander, U.S. Army Tank-Automotive Command, ATTN: AMSTA-MB, Warren, MI 48397-5000. A reply will be furnished to you. (Marine Corps) Submit NAVMC Form 10772 to the Commanding General, Marine Corps Logistic Base (Code 850), Albany, GA 31704-5000.

TA 267870

**LUBRICANT • INTERVAL**

**INTERVAL • LUBRICANT**

Front Differential Drain (See note 9) (LV-A) (O)

Pitman Arm (LV-D) (O)

Intermediate Steering Shaft (3 fittings) (LV-F, G) (O)

Crankcase Level (See note 4) (LV-H) (C)

Oil Filter (See note 5) (LV-K) (O)

Crankcase Drain (See note 4) (LV-L) (O)

Transfer Case Drain (See note 8) (LV-P) (O)

Transfer Case Fill and level (Check level) (See note 8) (LV-Q) (O)

Rear Differential Drain (See note 9) (LV-A) (O)

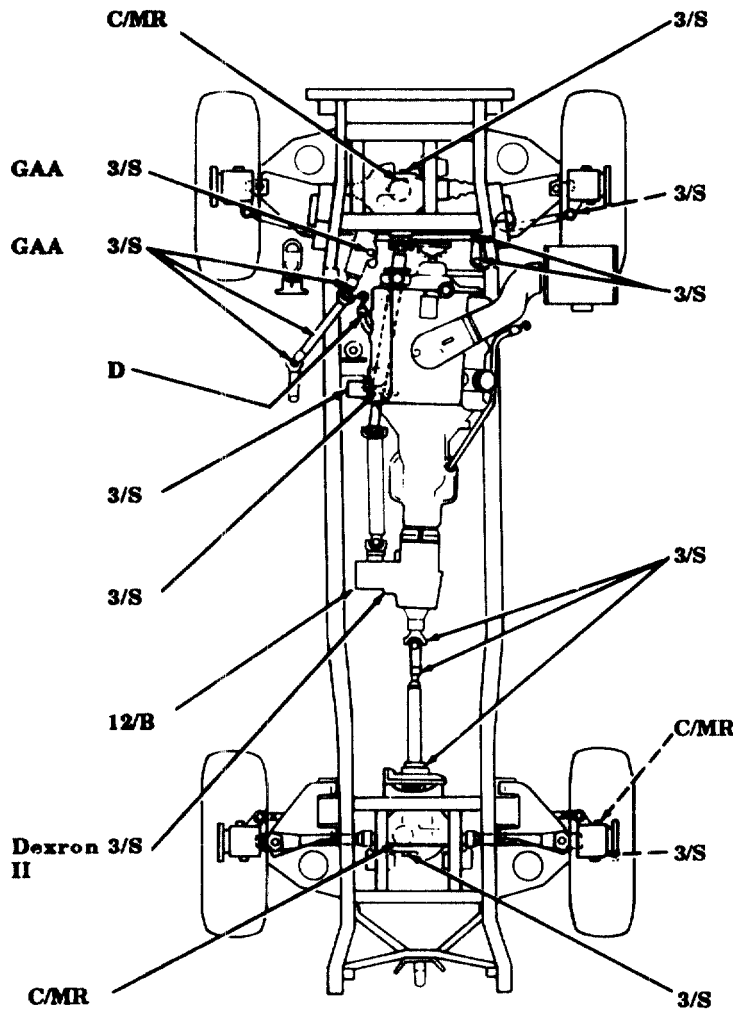

GO Front Differential Fill and Level (Check level) (See note 9) (LV-B) (O)

GAA Tie Rod Ends (2 fittings) (LV-C) (O)

GAA Idler Arm (2 fittings) (LV-E) (O)

GAA Rear Propeller Shaft Universal and Slip Joints (3 fittings) (See note 10) (LV-M, N) (O)

GO Rear Geared Hub Drain (See note 9) (LV-R) (O)

GO Rear Geared Hub Fill and Level (Check level) (See note 9) (LV-S) (O)

GO Rear Differential Fill and Level (Check level) (See note 9) (LV-B) (O)

**NOTE**

A REFERENCE TO THE LOCALIZED VIEW (LV) IS PROVIDED AFTER LUBRICATION POINT ENTRY.

TA 267871

**LUBRICANT • INTERVAL**

**INTERVAL • LUBRICANT**

**Front Geared Hub** GO  
**Fill and Level**  
 (Check level)  
 (See note 9)  
 (LV-S) (O)

**Front Geared Hub**  
**Drain**  
 (See note 9)  
 (LV-R) (O)

**Brake Master**  
**Cylinder** BFS  
 (See note 12)  
 (LV-W) (C)

**Power Steering**  
**Reservoir** Dexron M  
**Fill and Level** II  
 (Check level)  
 (See note 11)  
 (LV-Y) (C)

**Fuel Filter** 6/A  
 (See note 6)  
 (LV-AB) (O)

**Front Propeller**  
**Shaft Universal**  
**and Slip Joints** GAA  
 (3 fittings)  
 (See note 10)  
 (LV-U, V) (O)

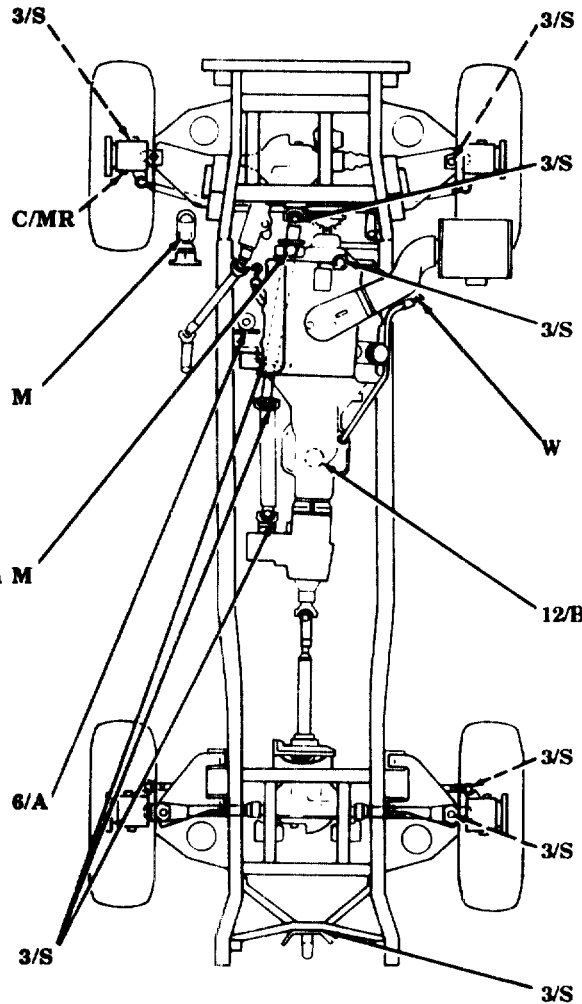

GAA Front Upper  
 Control Arm  
 Ball Joint  
 (LV-T) (O)

GAA Front Propeller  
 Shaft Universal  
 Joint  
 (See note 10)  
 (LV-U) (O)

OE/  
 HDO Crankcase  
 Fill  
 (See note 4)  
 (LV-X) (O)

Dexron  
 II Transmission  
 Fill and Level  
 (Check level)  
 (See note 7)  
 (LV-Z) (C)

Transmission  
 Drain  
 (See note 7)  
 (LV-AA) (O)

GAA Radius Rod  
 (LV-AC) (O)

GAA Rear Upper  
 Control Arm  
 Ball Joint  
 (LV-T) (O)

GAA Pintle  
 (See note 13)  
 (LV-AD) (O)

**NOTE**

A REFERENCE TO THE LOCALIZED VIEW (LV) IS  
 PROVIDED AFTER LUBRICATION POINT ENTRY.

TA 267872

**LUBRICANT • INTERVAL**

**INTERVAL • LUBRICANT**

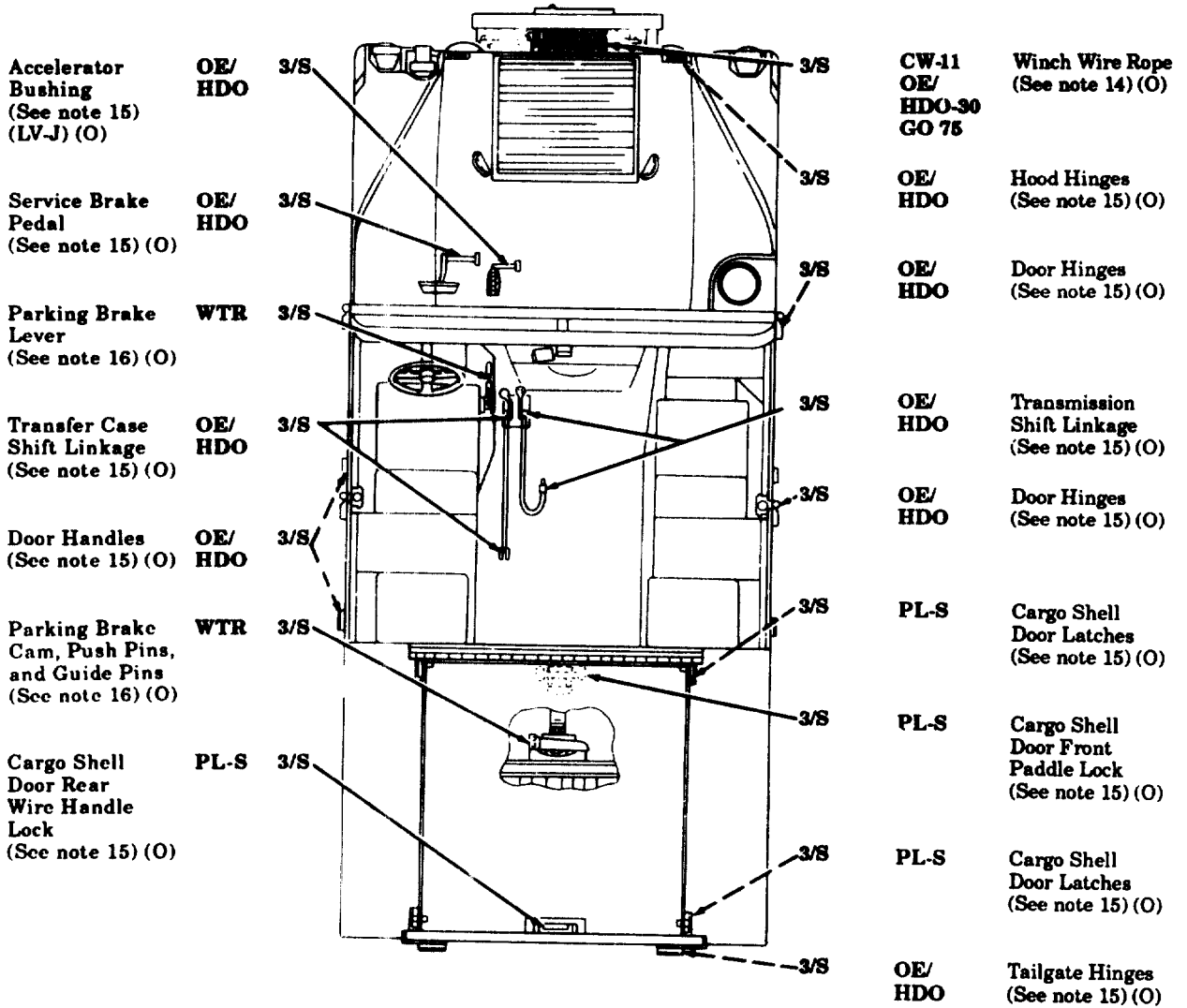

TA 267873

**LOCALIZED LUBRICATION POINTS (A THROUGH J)**

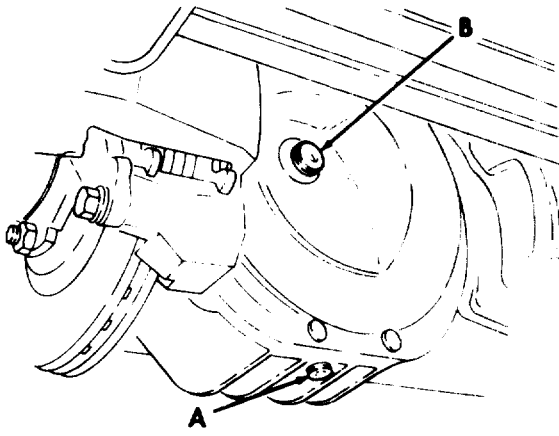

**DIFFERENTIAL**

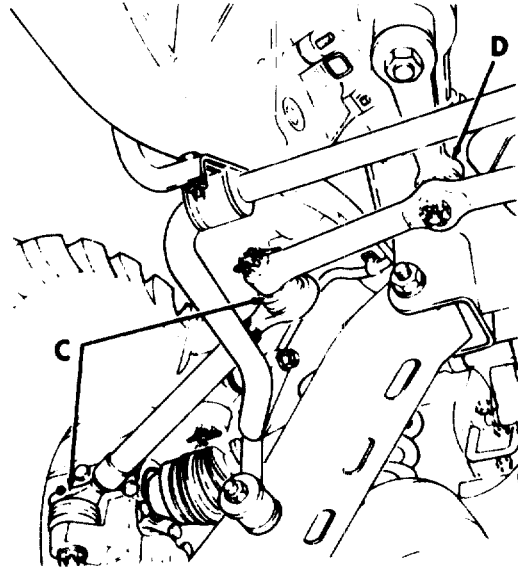

**TIE ROD AND PITMAN ARM**

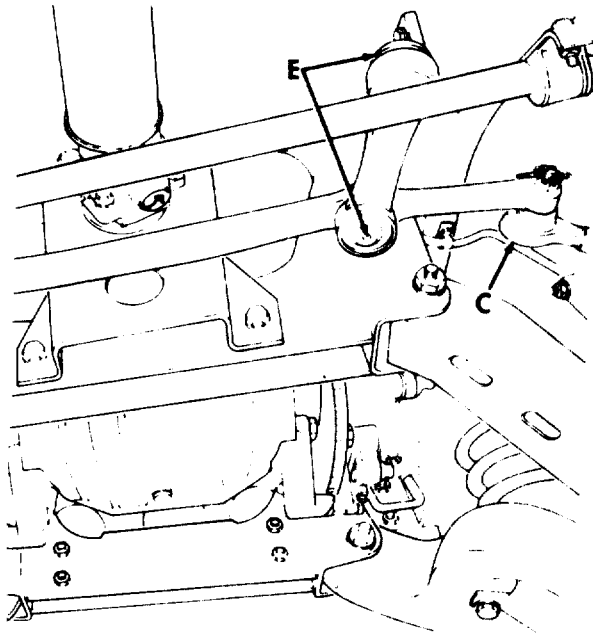

**IDLER ARM AND TIE ROD**

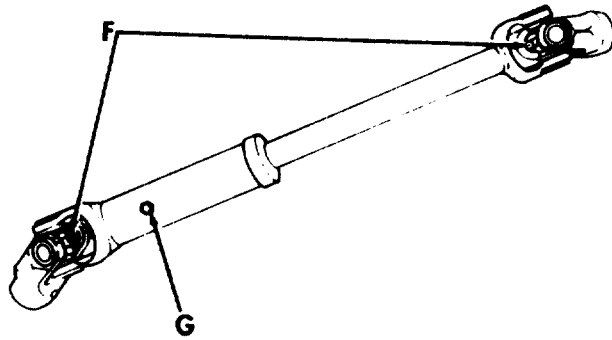

**INTERMEDIATE STEERING SHAFT**

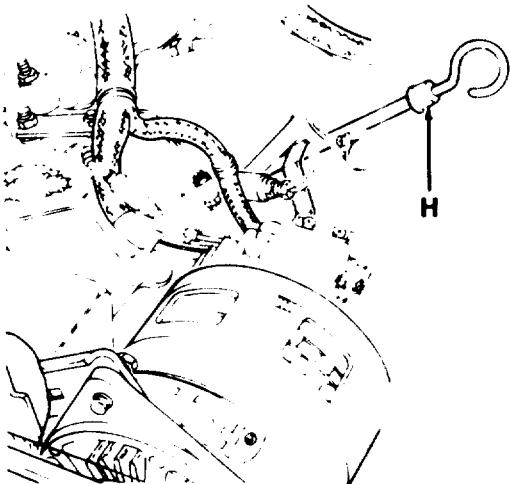

**CRANKCASE LEVEL**

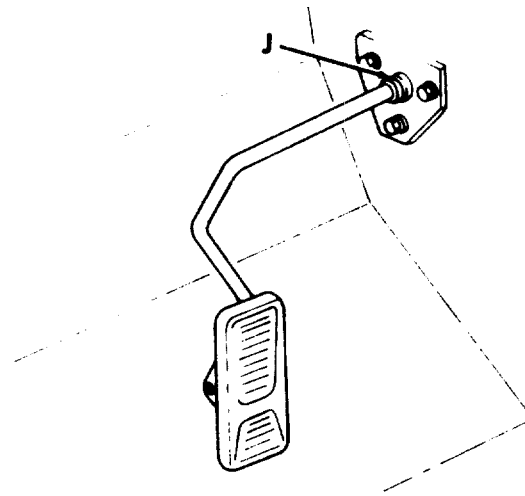

**ACCELERATOR LINKAGE**

TA 267874

LOCALIZED LUBRICATION POINTS (K THROUGH W)

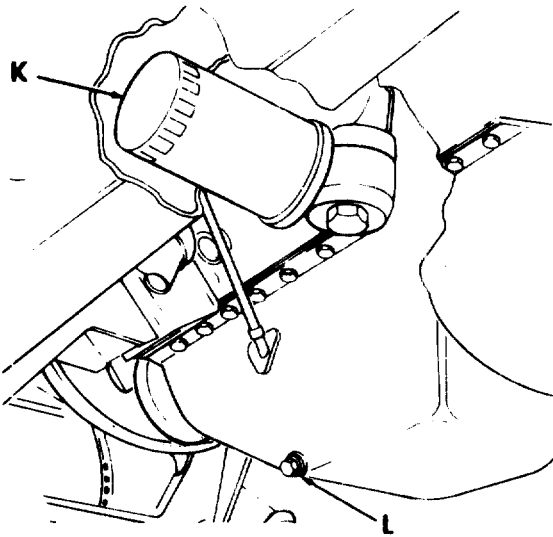

OIL FILTER AND CRANKCASE DRAIN

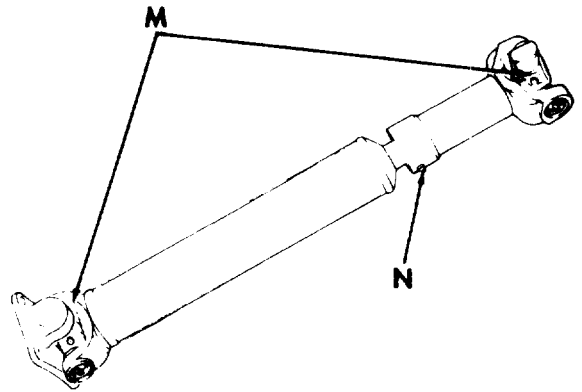

REAR PROPELLER SHAFT UNIVERSAL AND SLIP JOINTS

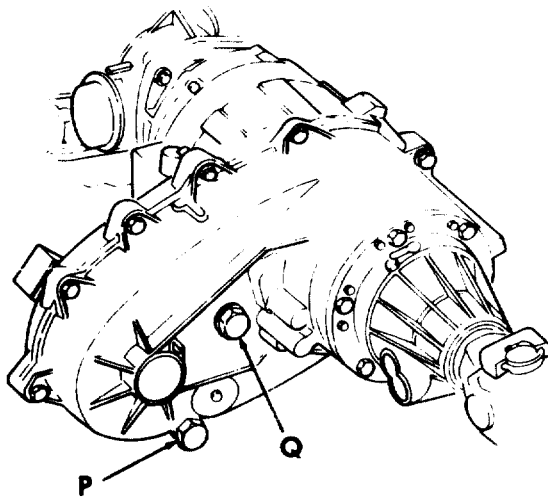

TRANSFER CASE

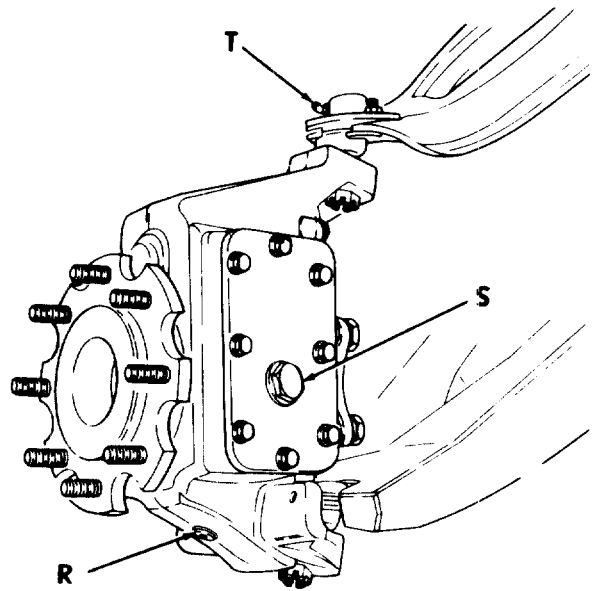

GEARED HUB AND UPPER CONTROL ARM BALL JOINT

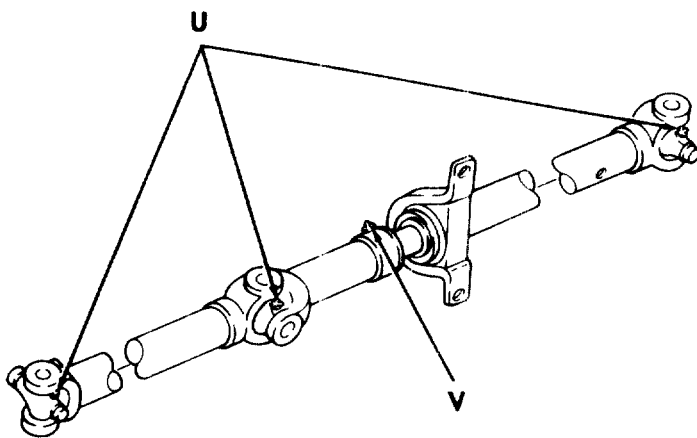

FRONT PROPELLER SHAFT UNIVERSAL AND SLIP JOINTS

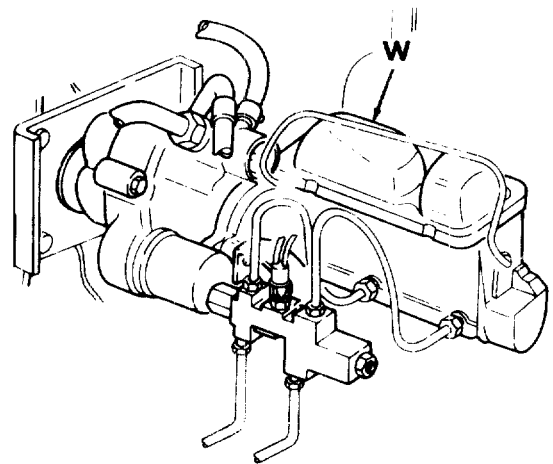

BRAKE MASTER CYLINDER

TA 267875

LOCALIZED LUBRICATION POINTS (X THROUGH AD)

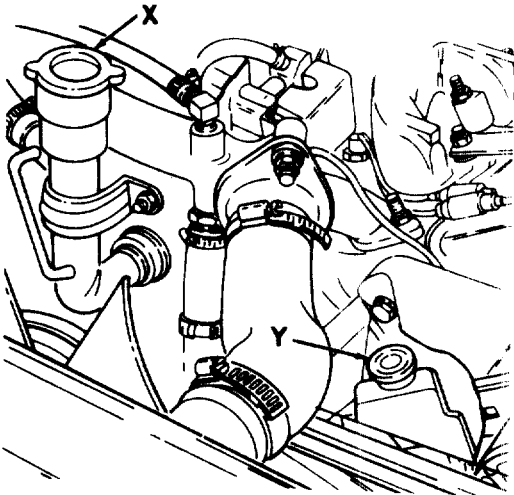

CRANKCASE FILL AND POWER STEERING  
RESERVOIR FILL AND LEVEL

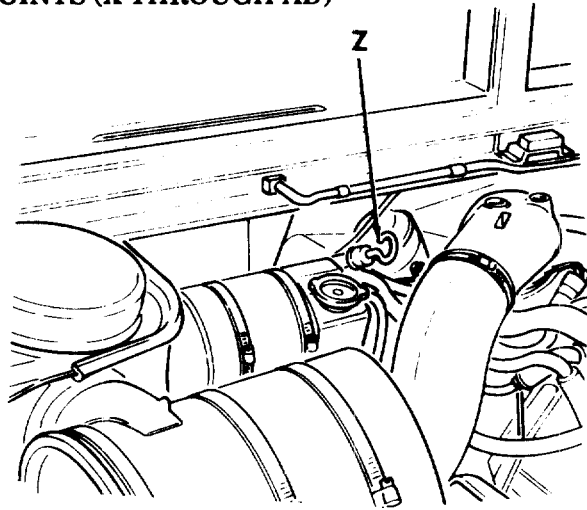

TRANSMISSION FILL AND LEVEL

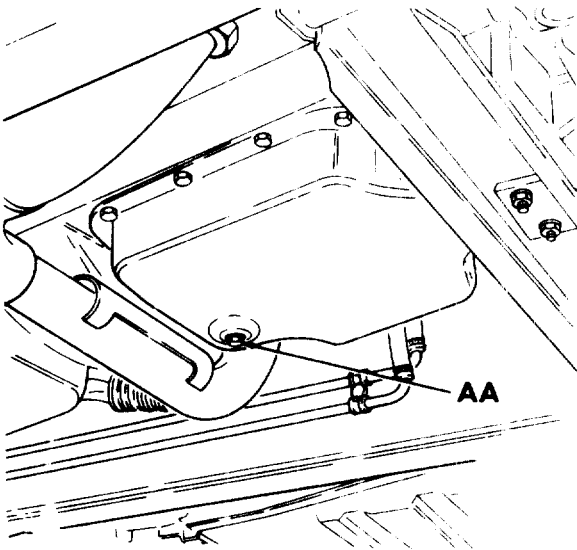

TRANSMISSION DRAIN

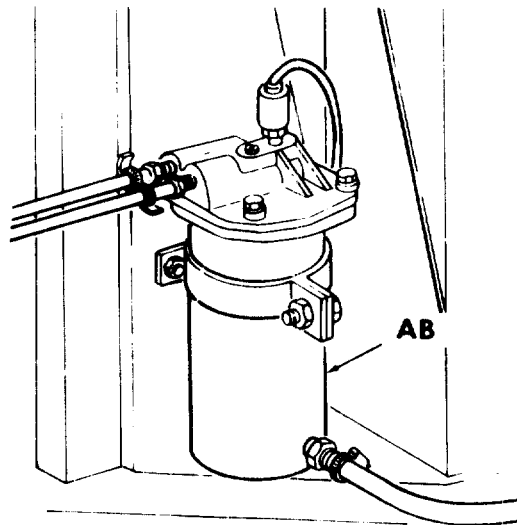

FUEL FILTER

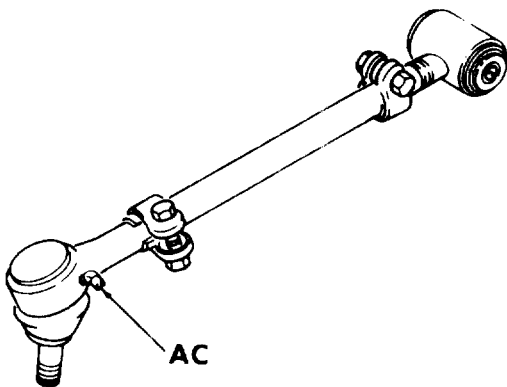

RADIUS ROD

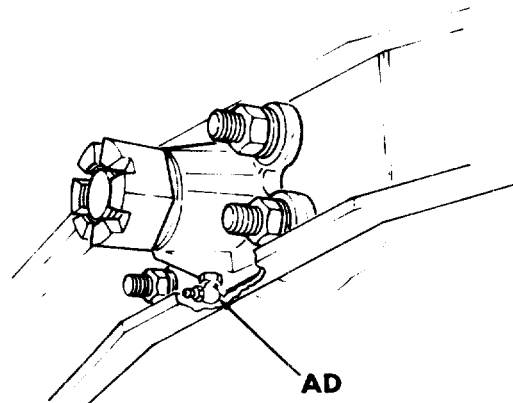

PINTLE

TA 267876



—KEY—

LUBRICANTS	CAPACITIES	EXPECTED TEMPERATURES			INTERVALS
		Above +15°F (Above -9°C)	+40° to -15°F (+4° to -26°C)	+40° to -65°F (+4° to -54°C)	
OE/HDO-LUBRICATING OIL, INTERNAL COM- BUSTION ENGINE, TACTICAL SERVICE (MIL-L-2104)  OEA-LUBRICATING OIL INTERNAL COM- BUSTION ENGINE, (ARCTIC) (MIL-L-46167)  OIL CAN POINTS  CRANKCASE: W/O FILTER W/FILTER  DRY SYSTEM (INCL. OIL COOLER)	          7 qt (6.6 l)  8 qt (7.6 l)  10 qt (9.5 l)	          OE/HDO 30* OE/HDO 30*	          OE/HDO 10** OE/HDO 10**	          OEA** OEA**	C/MR-Change gear lubricant only when required by mainte- nance repair action, or if contaminated by water or other foreign materials.  D-Daily  W-Weekly  M-Monthly  S/B-3,000 miles*** (4,800 km) or semiannually (6 months), which- ever occurs first.  6/A-6,000 miles (9,600 km) or annually (12 months), which- ever occurs first.  12/B-12,000 miles (19,200 km) or biennially (24 months), which- ever occurs first.
GO-LUBRICATING OIL, GEAR, MULTIPURPOSE (MIL-L-2105)  GEARED HUB (4)  DIFFERENTIAL (2)	      1 pt ea. (0.47 l)  2 qt ea. (1.9 l)	      GO 80/90 GO 80/90	      GO 80/90 GO 80/90	      GO 75 GO 75	
DEXRON II  TRANSMISSION DRY  DRAIN & REFILL  TRANSFER CASE  TOTAL STEERING SYSTEM WITH STEERING COOLER	          11 qt (10.4 l)  6 qt (5.7 l)  3.5 qt (3.3 l)  1 qt (0.96)  1.25 qt (1.18)	ALL TEMPERATURES			
BFS-BRAKE FLUID, SILI- CONE, AUTOMOTIVE, ALL WEATHER, OPER- ATIONAL AND PRESERVATIVE (MIL-B-461676)  BRAKE MASTER CYLINDER  TOTAL BRAKE SYSTEM	      0.60 pt (0.33 l)  1.2 pt (0.56 l)	ALL TEMPERATURES			
FOR ARCTIC OPERATION, REFER TO FM 9-207					

\* OE/HDO 15/40 (Grade 15W-40) lubricant may be used when expected temperatures are above +5°F (-15°C).  
 \*\* If OEA lubricant is required to meet the temperature ranges prescribed in the KEY, then the OEA lubricant is to be used in place of OE/HDO 10 lubricant for all temperature ranges.  
 \*\*\* If operating conditions are severe or abnormal, service chassis lubrication points at 1,000 miles (1,600 kilometers).

—KEY—(Cont'd)

LUBRICANTS	CAPACITIES	EXPECTED TEMPERATURES			INTERVALS	
		Above +15°F (Above -9°C)	+40° to -15°F (+4° to -26°C)	+40° to -65°F (+4° to -54°C)		
GAA-GREASE, AUTOMOTIVE AND ARTILLERY (MIL-G-10924)		ALL TEMPERATURES			FOR ARCTIC OPERATION, REFER TO FM 9-207	
PL-S-LUBRICATING OIL, GENERAL PURPOSE, PRESERVATIVE, (WATER DISPLACING LOW TEMPERATURE) (VV-L-800A)		ALL TEMPERATURES				
WTR-GREASE, AIRCRAFT, GENERAL PURPOSE, WIDE TEMPERATURE RANGE (MIL-G-81322)		ALL TEMPERATURES				
CW-LUBRICATING OIL, CHAIN WIRE ROPE, EXPOSED GEAR (VV-L-751)		ABOVE +80°F (+27°C)	+80° TO +30°F (+27, TO -1°C)	+30° TO -30°F (-1° TO -34°C)	-30° TO -65°F (-34° TO -55°C)	X
	WINCH WIRE ROPE	CW-11C	CW-11B	CW-11A	GO 75	

**FUEL REQUIREMENTS — TEMPERATURE LIMITS (VV-F-800)**

Grade DF2 Fuel For use above + 10°F (-12°C)\*  
 Grade DF-1\*\* For use below +10°F (-12°C) to above -20°F (-29°C)  
 Grade DF-A For use below -20°F (-29°C)

- \* Temperature limits may vary dependent on the cloud point of the actual DF-2 fuel being supplied in the geographical area.
- \*\* DF-1 is not normally procured in CONUS or OCONUS. Refineries will blend DF-2 with kerosene to meet temperature requirements of DF-1.

***TOTAL MAN-HOURS		***TOTAL MAN-HOURS	
INTERVAL	MAN-HOURS	INTERVAL	MAN-HOURS
C/MR	2.0	3/S	1.5
D	0.1	6/A	2.0
W	0.2	12/B	3.0
M	0.4		

\*\*\*The time specified is the time required to perform all services at the particular interval.

**NOTE**

The man-hours shown above have been established on an individual vehicle basis and, accordingly, are not applicable at maintenance facilities where production line methods are employed.

TA 267981

## NOTES

**1. Intervals.** This LO complies with DA programming to extend intervals and conserve lubricants. When practicable, lubrication services will be made to coincide with the vehicle's Semiannual ("S") Preventive Maintenance Service. For this purpose, a 10% tolerance (variation) in specified lubrication point mileage is permissible. Those vehicles not accumulating 1,000 mi (1,600 km) in a 6-month period will be lubricated at the time of "S" Preventive Maintenance Service.

**2. Army Oil Analysis Program (AOAP).** AOAP does not apply to M998 series vehicles.

**3. For Operation of Equipment in Protracted Cold Temperatures Below 5°F (-26°C).** Remove lubricants prescribed in key for temperatures above -15°F (-26°C). Relubricate with lubricants specified in key for temperatures below -15°F (-26°C). If OEA lubricant is required to meet the temperature ranges prescribed in the key, OEA lubricant is to be used in place of OE/HDO 10 lubricant for all temperature ranges where OE/HDO 10 is specified in the key.

### 4. Crankcase.

#### CAUTION

- There are two marks on the dipstick, "FULL" and "ADD 1 QT." The quantity of oil required to raise the oil level from "ADD 1 QT" mark to "FULL" mark is 1 qt (0.9 l). Do not overfill crankcase. Overfilling will result in damage to engine.
- If water or metal particles are detected during crankcase draining, notify Direct Support Maintenance personnel before refilling crankcase.

#### NOTE

- If oil level is above "FULL", it may be due to oil cooler drain back. Operate the engine for one minute, shut down, wait one minute, and recheck oil level.

- Replace oil filter each time crankcase is drained. Fill crankcase with 8 qt (7.6 l) of engine oil. Crankcase capacity is 7 qt (6.6 l) and oil filter capacity is 1 qt (0.9 l).
- Oil is added to crankcase through fill tube which is located on top-of engine.

Check crankcase oil level daily. Start engine and visually check for oil leaks at drain plug and oil filter. Stop engine and allow approximately one minute for oil to drain back into oil pan; recheck oil level with dipstick. On vehicles equipped for deep water fording, the dipstick has a seal which fits into the opening of the dipstick tube. The dipstick handle must be turned counterclockwise to be released before dipstick is withdrawn. Turn handle clockwise to seat after installing dipstick. Change oil every 3,000 mi (4,800 km) or semiannually, whichever occurs first.

### 5. Engine Oil Filter.

#### CAUTION

If water or metal particles are detected during oil filter replacement, notify Direct Support Maintenance personnel before refilling crankcase.

#### NOTE

Replace oil filter each time crankcase is drained.

Change oil filter every 3,000 mi (4,800 km) or semiannually, whichever occurs first.

**6. Fuel Filter.** Replace filter element every 6,000 mi (9,600 km) or annually, whichever occurs first. Replace water separator element if unserviceable.

## NOTES (Cont'd)

### 7. Transmission.

#### CAUTION

- Do not overfill transmission. The fluid level rises as the fluid temperature increases. Therefore, do not check level before the transmission has reached normal operating temperature. The safe operating level is within the crosshatch marks on the dipstick. Overfilling will result in damage to transmission.
- If water or metal particles are detected during transmission draining and filter element replacement, notify Direct Support Maintenance personnel before refilling transmission.
- Use Dexron II for filling transmission. Failure to use Dexron II will cause damage to transmission.

#### NOTE

Replace transmission oil filter each time transmission is drained. Fill transmission with 6 qt (5.7 l) of Dexron II.

Check and fill transmission to proper level weekly. Operate transmission through all operating ranges to fill cavities and fluid passages. With vehicle positioned on level ground, allow engine to idle, shift transmission to neutral, and apply parking brake. Check fluid level on dipstick. It should register within the crosshatch marks under the conditions stated above. On vehicles equipped for deep water fording, the dipstick has a seal which fits into the opening of the dipstick tube. The dipstick handle must be turned counterclockwise to be released before dipstick is withdrawn. Turn dipstick handle clockwise to seat after installing dipstick. Change fluid every 12,000 mi (19,200 km) or biennially, whichever occurs first.

### 8. Transfer Case.

#### CAUTION

- If water or metal particles are detected during transfer case draining, notify Direct Support Maintenance personnel before refilling transfer case.

- Use Dexron II for filling transfer case. Failure to use Dexron II will cause damage to transfer case.

#### NOTE

Fill transfer case with 3.5 qt (3.3 l) of Dexron II.

Check transfer case fluid level every 3,000 mi (4,800 km) or semiannually, whichever occurs first. Remove fill plug and gasket. Level should be within 1/2 in. (12.7 mm) of fill plug opening when vehicle is level. Install fill plug and gasket, and tighten to 35 lb-ft (47 N-m). Change fluid every 12,000 mi (19,200 km) or biennially, whichever occurs first.

### 9. Differentials and Geared Hubs.

#### NOTE

- Fill each axle differential with 2 qt (1.9 l) of GO.
- Fill each geared hub with 1 pt (0.5 l) of Go.

Check gear lubricant level every 3,000 mi (4,800 km) or semiannually, whichever occurs first. Geared hub level should be within 1/2 in. (12.7 mm) of fill plug opening, when lubricant is cold or to plug level when hot. Axle differential level should be within 1/4 in. (6.4 mm) of fill plug opening when lubricant is cold or to plug level when hot. Change gear lubricant only when required by maintenance repair action or if contaminated by water or other foreign material.

### 10. Propeller Shaft Universal and Slip Joints.

Every 3,000 mi (4,800 km) or semiannually, whichever occurs first, lubricate using low pressure lubrication gun. If operating conditions are severe or abnormal, service at 1,000 mi (1,600 km).

### 11. Steering Hydraulic System.

#### CAUTION

Use Dexron II for filling power steering reservoir. Failure to use Dexron II will cause damage to power steering system.

Check the fluid level in the power steering reservoir monthly and adjust level as necessary. If fluid is hot, level should be between "HOT" and "COLD" marks on the cap indicator. If cool, level should be between "ADD" and "COLD" marks. In either condition, level must be above "ADD" mark. Fluid does not require periodic changing.

## NOTES (Cont'd)

### 12. Brake Master Cylinder.

#### CAUTION

Use MIL-B-46176, Silicone Brake Fluid (BFS), for filling brake master cylinder. Failure to use BFS will cause damage to brake system

Check level monthly. Fill to approximately 1/8 in. (3.3 mm) from top of master cylinder reservoirs. Use BFS for brake master cylinder. Fluid does not require periodic changing.

**13. Pintle.** Every 3,000 mi (4,800 km) or semiannually, whichever occurs first, lubricate pintle at rear plate fitting. Every 6,000 mi (9,600 km) or annually, whichever occurs first, remove hook and latch pivot bolts and inspect for serviceability. Clean with wire brush and lubricate with seasonal grade OE/HDO.

### 14. Winch Wire Rope.

#### WARNING

Wear leather gloves when handling winch wire rope. Do not handle wire rope with bare hands. Broken wires cause injury.

After each use, clean and lubricate winch wire rope. Clean entire winch wire rope with wire brush. If used frequently, lubricate with clean OE/HDO 30. If used infrequently, or in very damp or salty conditions, lubricate with CW-II. Do not lubricate winch wire rope in dry, dusty conditions. If used in arctic conditions, lubricate with GO 75. Perform winch wire rope cleaning and lubrication every 3,000 mi (4,800 km) or semiannually, whichever occurs first, when wire rope is not used.

By Order of the Secretary of the Army:

Official:

**WILLIAM J. MEEHAN II**  
Brigadier General, United States Army  
The Adjutant General

By Order of the Secretary of the Air Force:

**CHARLES C. McDONALD**  
General, United States Air Force  
Commander, Air Force Logistics Command

By Order of the Marine Corps:

Distribution:

To be distributed in accordance with DA Form 12-38-E, Operator maintenance requirements for LO 9-2320-280-12.

**15. Oil Can Points.** Every 3,000 mi (4,800 km) or semiannually, whichever occurs first, perform the following: lubricate hood hinges, tailgate hinges, door hinges, door handles, service brake pedal pushrod stud, transfer case shift linkage, accelerator bushing, and transmission shift linkage with seasonal grade OE/HDO: lubricate cargo shell door front paddle lock, rear wire handle lock, and latches with PL-S (M966, M1025, M1026, M1036, M1043, M1044, M1045, and M1046 only).

**16. Parking Brake Lubrication.** On vehicles equipped with a single parking brake assembly mounted between the rear propshaft and rear differential: lubricate parking brake lever, parking brake cam, parking brake push pins, and parking brake guide pins with WTR. On vehicles equipped with a left and right parking/service brake assembly mounted between the rear axle half-shafts and rear differential, lubricate the parking brake lever with WTR. The parking/service brake assembly needs no lubrication.

**17. Do Not Lubricate.** Shock absorber bushings, radius rod bushings, stabilizer bar bushings, or suspension arm pivot bushings.

**18. Operator Participation.** "D", "W", and "M" maintenance is performed by the operator. Operator may assist in other lubrication intervals if supervised by qualified personnel.

*Copy of this lubrication order will remain with the vehicle at all times. Instructions contained herein are mandatory.*

**CARL E. VUONO**  
General, United States Army  
Chief of Staff

**LARRY D. WELCH**  
General, United States Air Force  
Chief of Staff

**H. E. REESE**  
Deputy for Support  
Marine Corps Research,  
Development and  
Acquisition Command

