

**ROUTINE**

**MWO effective date is 1 January 1996 and completion date is 31 December 1999.**

**MWO 9-2320-280-20-4**

**MODIFICATION WORK ORDER**

---

**MODIFICATION OF 1-1/4 TON VEHICLES  
M998 SERIES  
STEERING COLUMN INSPECTION AND BRACKET INSTALLATION**

---

<b>NOMENCLATURE</b>	<b>NSN</b>	
Truck, Utility, 1-1/4 Ton, 4x4:		
Cargo/Troop Carrier	2320-01-107-7155	(EIC: BBD)
Cargo/Troop Carrier, w/Winch	2320-01-107-7156	(EIC: BBE)
TOW Carrier, Armored	2320-01-107-7153	(EIC: BBC)
TOW Carrier, Armored, w/Winch	2320-01-107-7154	(EIC: BBH)
Armament Carrier, Armored	2320-01-128-9551	(EIC: BBF)
Armament Carrier, Armored, w/Winch	2320-01-128-9552	(EIC: BBG)
Armament Carrier, w/Supplemental Armor	2320-01-128-7190	
S250 Shelter Carrier	2320-01-146-7187	
TOW Carrier, w/Supplemental Armor, w/Winch	2320-01-146-7188	
Armament Carrier, w/Supplemental Armor, w/Winch	2320-01-146-7189	
TOW Carrier, w/Supplemental Armor	2320-01-146-7191	
S250 Shelter Carrier, w/Winch	2320-01-146-7193	(EIC: BBK)
Heavy Variant	2320-01-346-9317	(EIC: BBM)
Truck, Ambulance, 4x4:		
4-Litter, Armored	2310-01-111-2274	(EIC: BBA)
2-Litter, Armored	2310-01-111-2275	(EIC: BBB)
2-Litter, Soft top	2310-01-146-7194	

---

**Headquarters, Department of the Army, Washington, D.C.**

15 April 1996

**REPORTING OF ERRORS AND RECOMMENDING IMPROVEMENTS**

You can help improve this MWO. If you find any mistakes or if you know of a way to improve these procedures, please let us know. Mail your letter or DA Form 2028, Recommended Changes to Publications and Blank Forms, Direct to: U.S. Army Tank-Automotive Command, ATTN: AMSTA-MB, Warren, MI 48397-5000. A reply will be provided to you.

**APPROVED FOR PUBLIC RELEASE; DISTRIBUTION IS UNLIMITED.**

**1. PURPOSE.**

This modification provides a method to inspect steering columns and install steering column brackets for model 12338621-1, collapsible steering columns. The inspection will ensure that steering column brackets are installed on each acceptable steering column. The brackets will prevent the collapsible steering column from wearing and cracking at mounting points and becoming loose.

**2. PRIORITY.**

This modification is classified as ROUTINE.

**3. END ITEM TO BE MODIFIED.**

a. Truck, 1-1/4 Ton, 4x4, M998 Series, serial numbers 100,000 through 129,373, inclusively, without steering column brackets installed.

NOMENCLATURE	NSN	PART NO.	CAGEC	MODEL NO.
Truck, Utility, 1-1/4 ton, 4x4:				
Cargo/Troop Carrier	2320-01-107-7155	8750057	19207	M998
Cargo/Troop Carrier, w/W	2320-01-107-7156	8750058	19207	M1038
TOW Carrier, Armored	2320-01-107-7153	8750055	19207	M966
TOW Carrier, Armored, w/W	2320-01-107-7154	8750056	19207	M1036
Armament Carrier, Armored	2320-01-128-9551	8750082	19207	M1025
Armament Carrier, Armored, w/W	2320-01-128-9552	8750083	19207	M1026
S250 Shelter Carrier	2320-01-146-7187	8750124	19207	M1042
TOW Carrier, w/Supp armor, w/W	2320-01-146-7188	8750123	19207	M1046
Armament Carrier, w/Supp Armor, w/W	2320-01-146-7189	8750122	19207	M1044
Armament Carrier, w/Supp Armor	2320-01-146-7190	8750121	19207	M1043
TOW Carrier, w/Supp Armor	2320-01-146-7191	8750120	19207	M1045
S250 Shelter Carrier, w/Winch	2320-01-146-7193	8750117	19207	M1037
Heavy Variant	2320-01-346-9317	8750236	19207	M1097
Truck, Ambulance, 4x4:				
4-Litter, Armored	2320-01-111-2274	8750059	19207	M997
2-Litter, Armored	2310-01-111-2275	8750060	19207	M996
2-Litter, Soft Top	2310-01-146-7194	8750116	19207	M1035

b. Vehicle National Stock Number (NSN) will not change as a result of this MWO.

**4. MODULE TO BE MODIFIED.**

Not applicable.

**5. PARTS TO BE MODIFIED.**

Not applicable.

**6. APPLICATION.**

a. Time Compliance Schedule: The effective date of this MWO is 1 January 1996 and its completion date is 31 December 1999.

b. The lowest level of maintenance authorized to apply the MWO is organizational.

c. Work force and man-hour requirements for application of this MWO to a single unit, end item, or system:

REQUIREMENTS	
WORK FORCE/SKILLS	MAN-HOURS
1 Wheeled Vehicle Mechanic (MOS 63W) or equivalent	0.8
Total man-hours required for a single application of the MWO is 0.8 hours.	

**7. TECHNICAL PUBLICATIONS AFFECTED/CHANGED AS A RESULT OF THE MWO.****Technical Publication**

TM 9-2320-280-20-2  
 TM 9-2320-280-20P  
 TM 9-2320-280-34P

**Date**

19 Jan 90  
 22 Aug 91  
 22 Aug 91

**8. MWO KITS, PARTS, AND THEIR DISPOSITION.**

a. The following kit is required to accomplish this modification. The security classification of this kit is unclassified. Shipping data is: weight 1.1 lbs; the kit measures 5.3 x 4.0 x 1.5 in.; its volume is 0.018 cu ft.

NSN	NOMENCLATURE	CAGEC	PART NO.
2510-01-399-5280	Steering Column Bracket Modification Kit	19207	57K0286

b. Steering Column Bracket Modification Kit parts are listed below. The list is used to inventory the kit for completeness.

NSN	NOMENCLATURE	CAGEC	PART NO.	QTY.
9905-00-858-5682	Plate, Instruction, MWO	19207	10930014	1
	Bracket	19207	12342875	1
	Bracket	19207	12342876	1
9305-00-253-5614	Screw	96906	MS21318-20	1
5310-00-809-4058	Washer	96906	MS27183-10	2
5310-00-061-4650	Nut	96906	MS51943-31	3
5305-00-225-3843	Screw	05047	B1821BH025C100N	1
5305-00-582-9501	Screw	11862	431942	1
5310-00-124-9265	Nut	72582	271169	1

c. Bulk and expendable material not applicable to this MWO.

d. Parts disposition. All parts not used during installation will be returned to stock for disposition in accordance with AR 725-50.

**9. SPECIAL TOOLS; TOOL KITS; JIGS; TEST, MEASUREMENT AND DIAGNOSTIC EQUIPMENT (TMDE); AND FIXTURES REQUIRED.**

a. The following listed tool set contains the necessary hand tools to apply the MWO:

NOMENCLATURE	NSN	CAGEC	SUPPLY CATALOGUE
Tool Kit, General Mechanic's	5180-00-177-7033	50980	SC 5180-90-CL-N26

b. Metal drilling equipment necessary to apply MWO is contained in this set:

NOMENCLATURE	NSN	CAGEC	SUPPLY CATALOGUE
Shop Equipment, Automotive Maintenance and Repair Common No. 1	4910-00-754-0654	19204	SC 4910-95-CL-A74

**10. MODIFICATION PROCEDURES.**

a. VEHICLE PREPARATION.

- (1) Apply parking brake. (Refer to TM 9-2320-280-10.)
- (2) If installed, remove driver's side front door. (Refer to TM 9-2320-280-20.)
- (3) Place driver's seat to the furthest rear position. (Refer to TM 9-2320-280-10.)

b. STEERING COLUMN INSPECTION.

- (1) Loosen nut on pin and place steering column in down position on mounting support as shown in figure 1.

**WARNING**

**When checking tab inserts at end of steering column, do not allow steering column to slip from support bracket. Steering column can fall causing injury to personnel.**

- (2) Remove two shoulder bolts, washers, and nuts from steering column as shown in figure 2.
- (3) Check tab inserts at end of steering column for paint and metal cracking as shown in figure 2. If cracking is present on or around tab inserts, discontinue inspection procedure and replace steering column (Refer to TM 9-2320-280-20).

**NOTE**

- **Check shoulder bolts removed in step "2" for "mushrooming" around shaft area of shoulder bolt as shown in figure 2. If mushrooming is present, replace shoulder bolts, washers, and nuts (Refer to TM 9-2320280-20).**
- **If mushrooming is not present, perform step "4".**

- (4) Install two existing shoulder bolts, washers, and two MS51943-31 nuts as shown in figure 2. Tighten nuts to 10 lb-ft (14 N-m).

c. STEERING COLUMN BRACKET INSTALLATION.

- (1) Remove screw, nut, and ground lead 57C from steering column as shown in figure 1.
- (2) Secure ground lead 57C and 12342875 bracket to steering column with 431942 screw and 271169 nut as shown in figure 3. Do not tighten nut.
- (3) Secure 12342876 bracket to bracket (12342875) and steering column with B1821BH025C1OON screw, two MS27183-10 washers, and MS51943-31 nut as shown in figure 3. Tighten nut to 10 lb-ft (14 N•m).
- (4) Tighten nut (271169) installed in step "2" as shown in figure 3.
- (5) Place steering column and pin in upward position on mounting support until steering column cannot be raised any further as shown in figure 5. Tighten nut on pin to 14 lb-ft (19 N•m).

(6) If removed, install driver's side front door.

**11. CALIBRATION REQUIREMENTS.**

Not applicable.

**12. WEIGHT AND BALANCE DATA.**

Weight and balance are not significantly affected by this MWO.

**13. QUALITY ASSURANCE REQUIREMENTS.**

The installer is responsible for the following instructions in MWO 9-2320-280-20-4. The installer will report modification kits received that are damaged or have missing component parts, so the supplier can be properly notified. The installer is responsible for functional testing of installed modification kit. Any discrepancies noted will be corrected before the vehicle leaves the installer's work area.

**14. RECORDING AND REPORTING OF THE MODIFICATION.**

a. Records and reports. (Refer to DA PAM 738-750.)

b. Marking Equipment.

(1) After Steering Column Bracket Modification Kit is installed, mark MWO number "9-2320-280-20-4" in the MWO Applied Block and date applied in Date Block on MWO Instruction Plate 10930014.

**NOTE**

**Do not remove any existing MWO Instruction Plates affixed to the reinforcement panel.**

(2) Install 10930014 MWO instruction plate by drilling a 0.104-inch diameter hole within designated area on body reinforcement panel and secure with MS21318-20 drive screw as shown in figure 4.

(3) After drive screw is installed, flatten or remove any protruding drive screw material from inside of body reinforcement panel.

c. Identification Data.

Not applicable.

**15. MATERIAL CHANGE (MC) NUMBER.**

The MWO is authorized by Material Change (MC) number 1-93-06-4456.

**16. MODIFICATION IDENTIFICATION.**

a. When installed correctly, the steering column brackets will appear as shown in figure 5.

b. After the steering column brackets are installed, the steering column should be tested for secure mounting. Any faults detected or discrepancies noted will be corrected before the vehicle is returned to normal service.

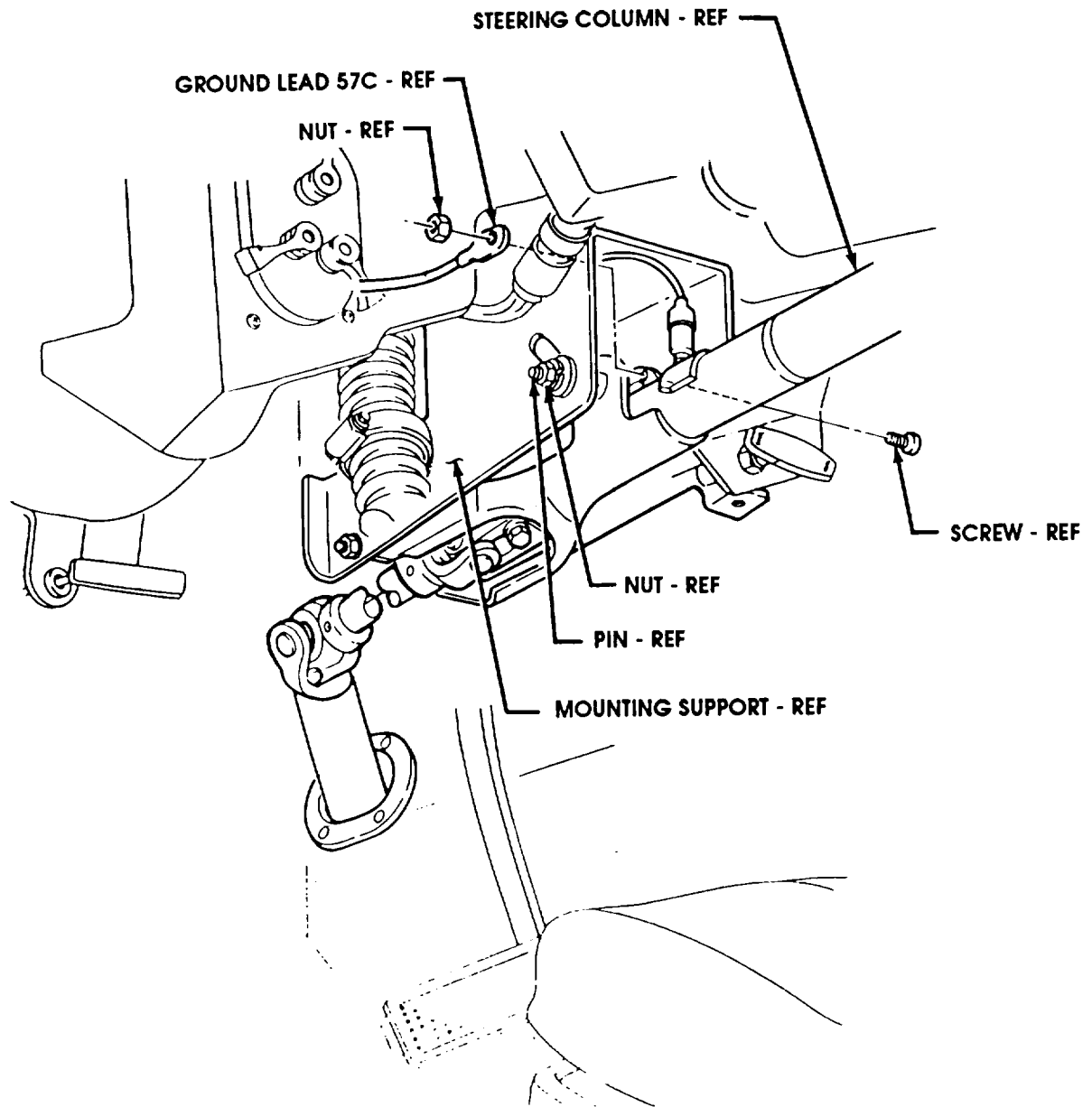

FIGURE 1

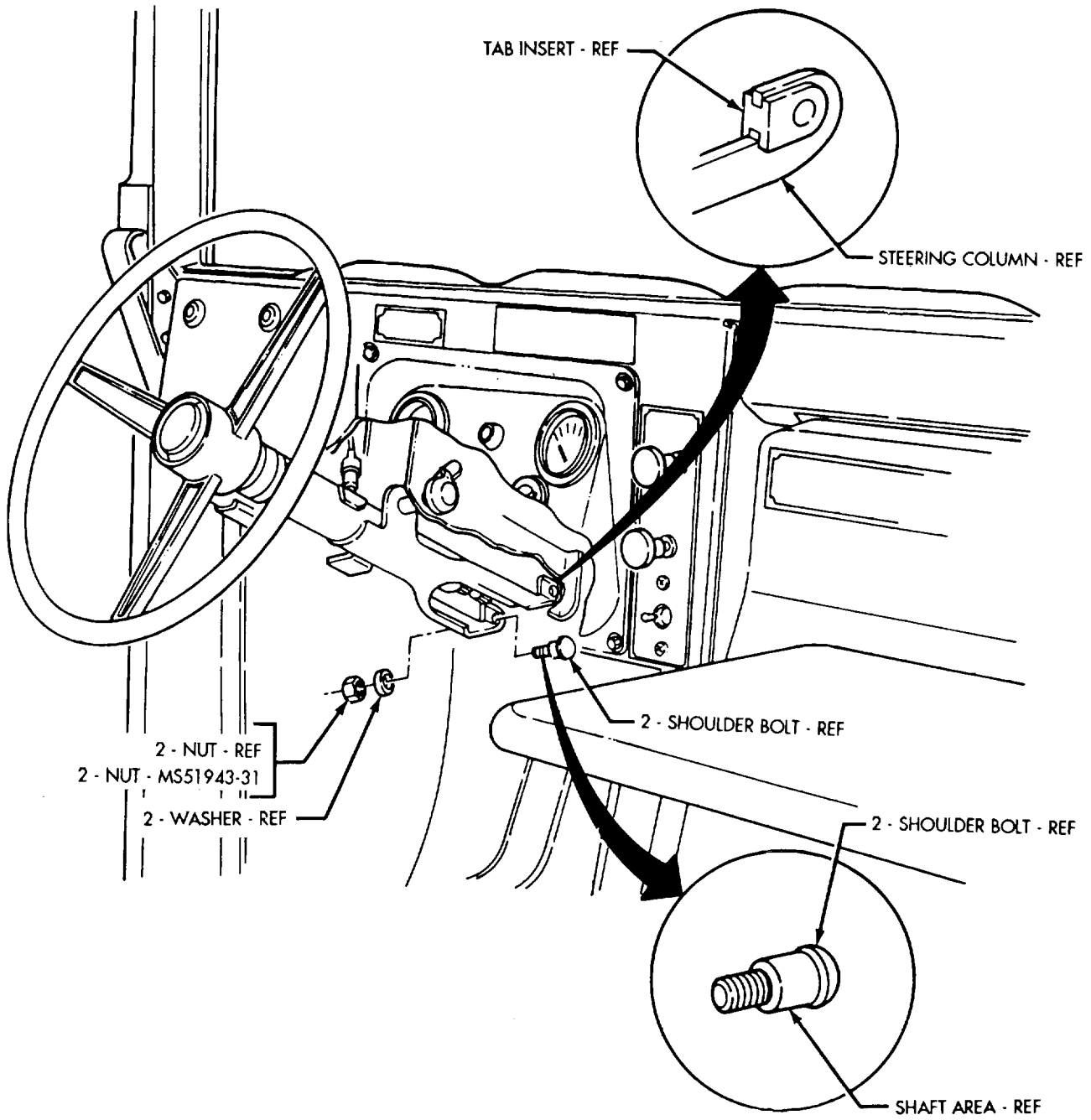

FIGURE 2

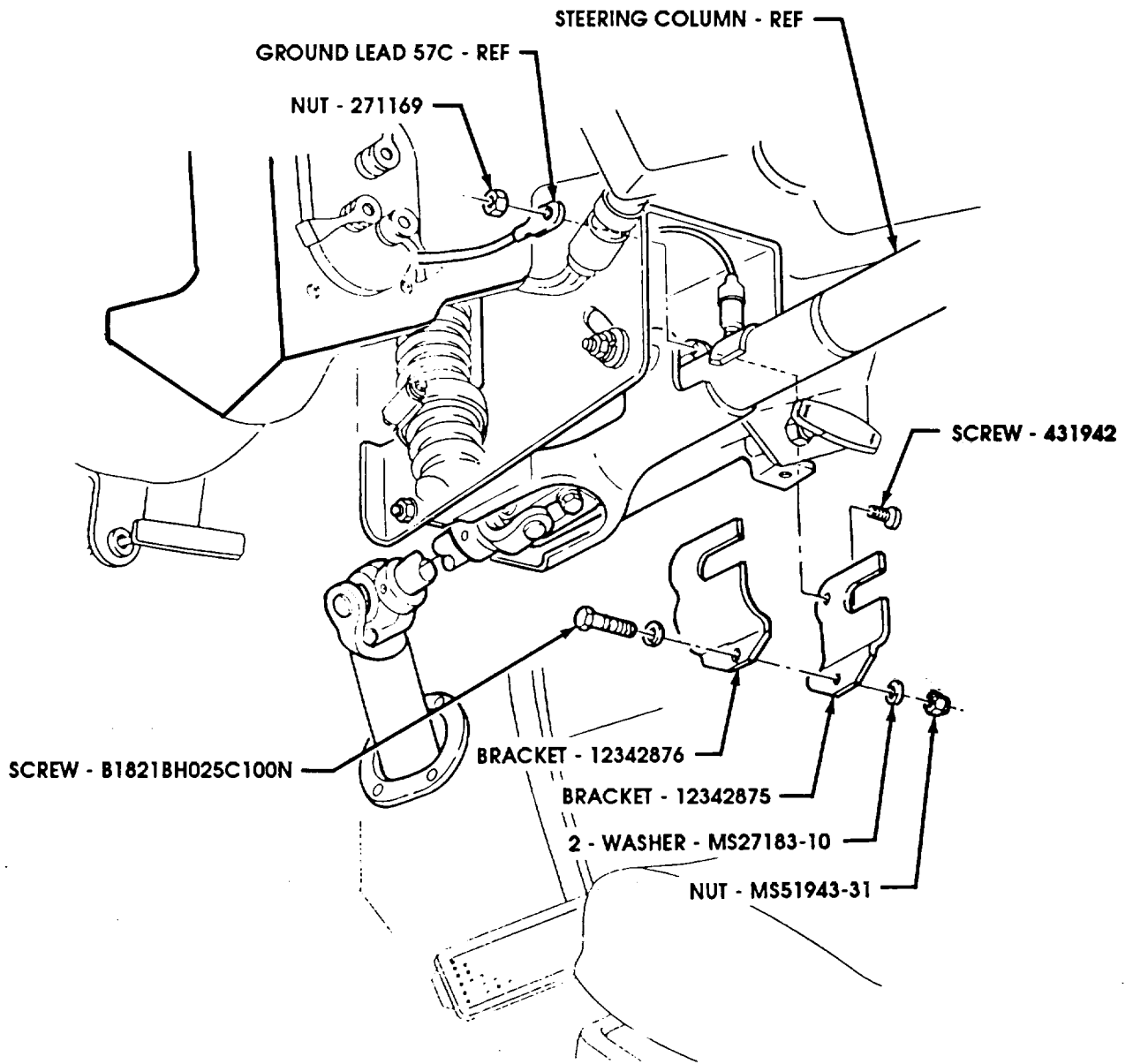

FIGURE 3



ALL DIMENSIONS ARE IN INCHES

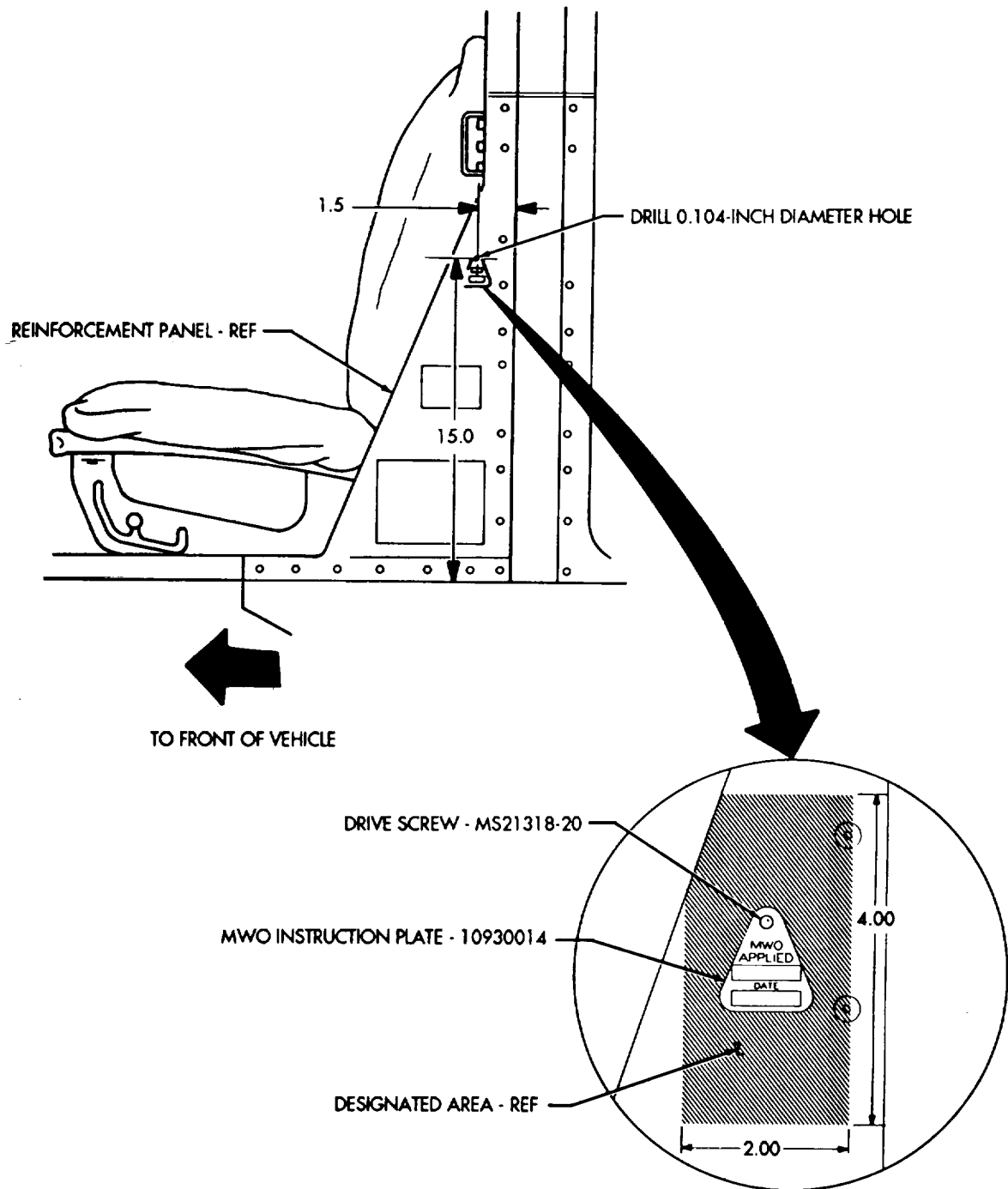

FIGURE 4

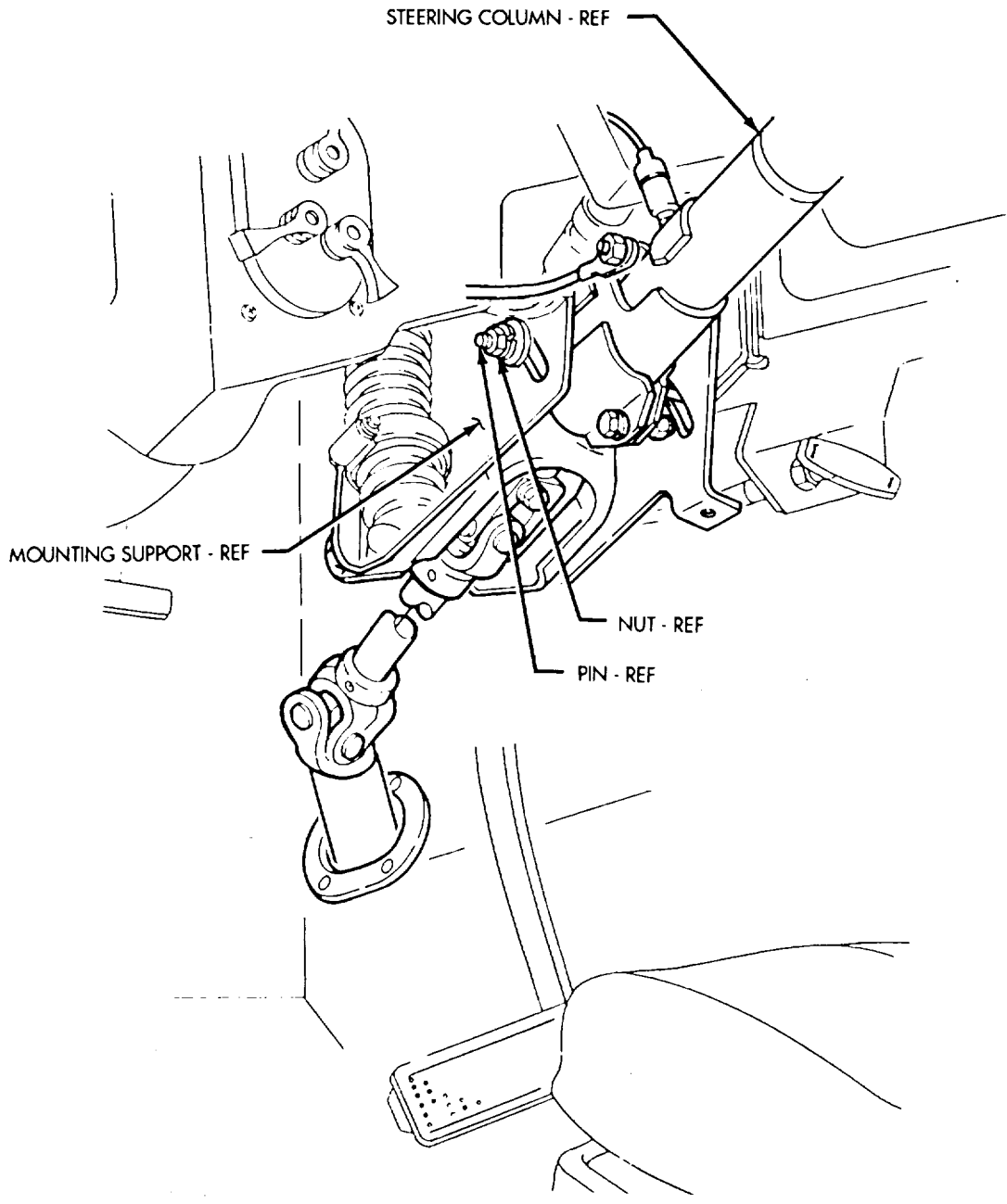

FIGURE 5

By Order of the Secretary of the Army:

DENNIS J. REIMER  
*General, United States Army*  
*Chief of Staff*

Official:



JOEL B. HUDSON  
*Administrative Assistant to the*  
*Secretary of the Army*  
01987

DISTRIBUTION:

To be distributed in accordance with DA Form 12-38-E, block 1010,  
requirements for MWO 9-2320-280-20-4.

\* U.S. GOVERNMENT PRINTING OFFICE: 1996 646-018/20204

RECOMMENDED CHANGES TO EQUIPMENT TECHNICAL PUBLICATIONS



THEN... JOT DOWN THE DOPE ABOUT IT ON THIS FORM, CAREFULLY TEAR IT OUT, FOLD IT AND DROP IT IN THE MAIL!

**SOMETHING WRONG WITH THIS PUBLICATION?**

FROM: (PRINT YOUR UNIT'S COMPLETE ADDRESS)

DATE SENT

PUBLICATION NUMBER

PUBLICATION DATE

PUBLICATION TITLE

BE EXACT... PIN-POINT WHERE IT IS

PAGE NO.

PARA-GRAPH

FIGURE NO.

TABLE NO.

IN THIS SPACE TELL WHAT IS WRONG AND WHAT SHOULD BE DONE ABOUT IT:

TEAR ALONG PERFORATED LINE

PRINTED NAME, GRADE OR TITLE, AND TELEPHONE NUMBER

SIGN HERE:

DA FORM 2028-2  
1 JUL 79

PREVIOUS EDITIONS ARE OBSOLETE.

P.S.—IF YOUR OUTFIT WANTS TO KNOW ABOUT YOUR RECOMMENDATION MAKE A CARBON COPY OF THIS AND GIVE IT TO YOUR HEADQUARTERS.

**PIN: 074700-000**